



# BALL BEARING TURNTABLES

**Forged**

MADE IN GERMANY

## Low maintenance Single Row - Forged

Made in Germany

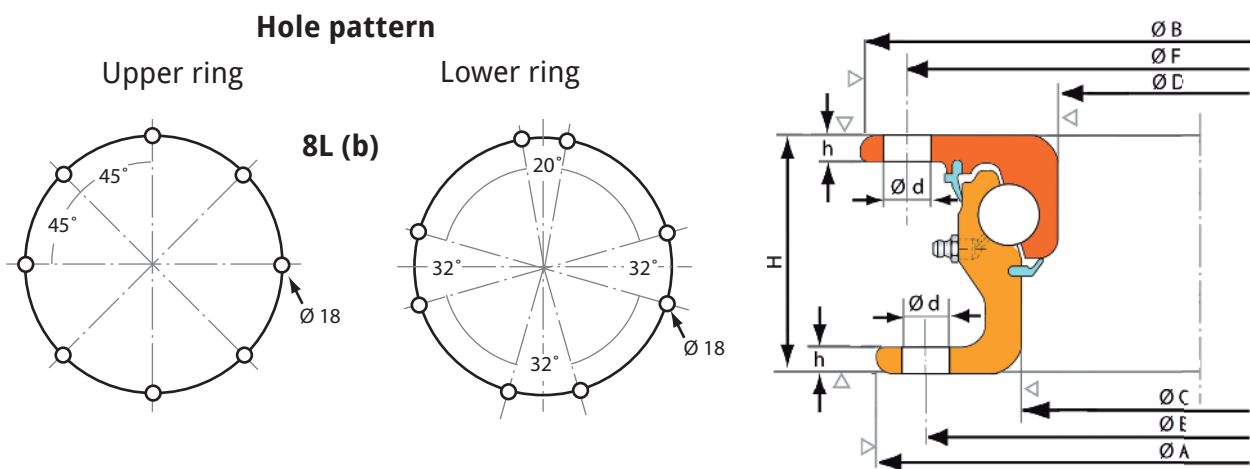

Type	Ø A mm	Ø B mm	Ø C mm	Ø D mm	Ø E mm	Ø F mm	h mm	H mm	Weight (kg)	Axial- loads (t)	Hole pattern
HB 90/1100.22 W	1100	1108	985	954	1060	1074	10	90	71	12	8L (b)
HB 90/1100.24 W	1100	1108	985	954	1060	1074	10	90	71	16	8L (b)
HB 90/1200.22 W	1200	1208	1085	1054	1160	1174	10	90	79	14	8L (b)
HB 90/1200.24 W	1200	1208	1085	1054	1160	1174	10	90	79	18	8L (b)
HB 90/1300.22 W	1300	1308	1185	1154	1260	1274	10	90	87	16	8L (b)

Please note our installation and maintenance instructions

(W) = Low-maintenance version with two sealing lips available. The specified load capacity is calculated for three-axle truck trailers. For two-axle truck trailers, the stated carrying capacity may be exceeded by 10%; at speeds below 25 km / h, this value may be exceeded by up to 20%. The W ball bearing wreaths are designed for a maintenance-free service life of up to 300,000 km or 3 years, depending on the first entry.

Nevertheless, depending on the environment of use, the sealing lips should be inspected periodically for damages and the rings and balls should be controlled for adequate lubrication, especially when used in extremely dusty environments or if the turntables are improperly cleaned, e.g. through intensive use of high-pressure cleaners, foreign bodies can penetrate into the closed lubrication system. In this case, or after expiry of the maintenance-free service life, the ball races can be relubricated via the grease nipples.

## Series HB - Heavy Duty Double Row - Forged

*Made in Germany*

### Hole pattern

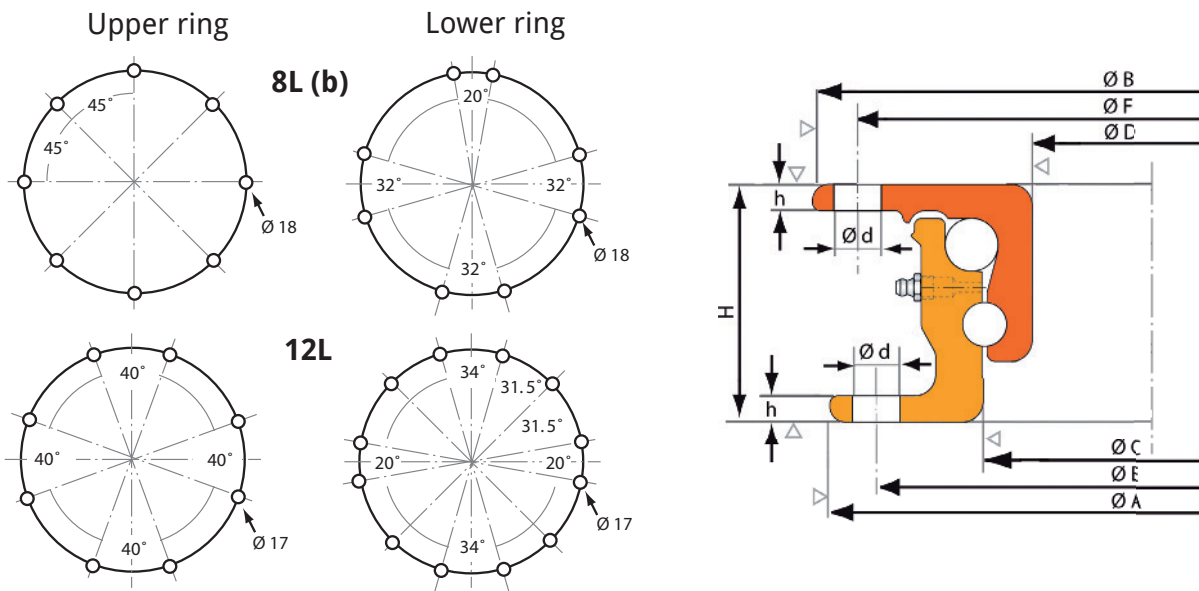

Type	$\varnothing A$ mm	$\varnothing B$ mm	$\varnothing C$ mm	$\varnothing D$ mm	$\varnothing E$ mm	$\varnothing F$ mm	h mm	H mm	Weight (kg)	Axial- loads (t)	Hole pattern
HB 90/16-1000	987	1000	871	834	952	1074	10	90	82	16	8L (b)
HB 90/20	1095	1108	979	942	1060	1074	10	90	92	20	8L (b)
HB 90/20-1208	1195	1208	1079	1042	1160	1174	10	90	101	20	8L (b)
HB 90/20-1212	1195	1208	1079	1042	1160	1174	10	90	101	20	12L
HB 90/30-1212	1195	1208	1179	1142	1160	1274	10	90	101	30	12L

Please note our installation and maintenance instructions

## Helmut Buer GmbH & Co. KG

- Ball Bearing Turntables
- Vehicle Components
- Wheels & Rims
- Valves & Accessories
- Vehicle-trailer Couplings.
- and more...



Helmut Buer GmbH & Co. KG  
Am Leveloh 11  
D-45549 Sprockhövel

Tel: +49(0)2324/90291-0  
Fax: +49(0)2324/77 33-0  
Email: [info@buer-kg.de](mailto:info@buer-kg.de)  
Web: [www.buer-kg.de](http://www.buer-kg.de)