

Series ND

Z-Profile

Drilling pattern

Upper ring

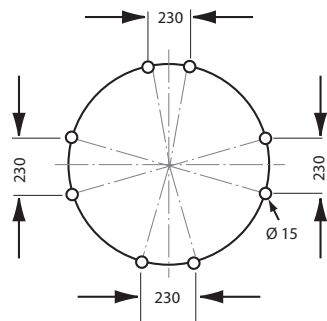

Lower ring

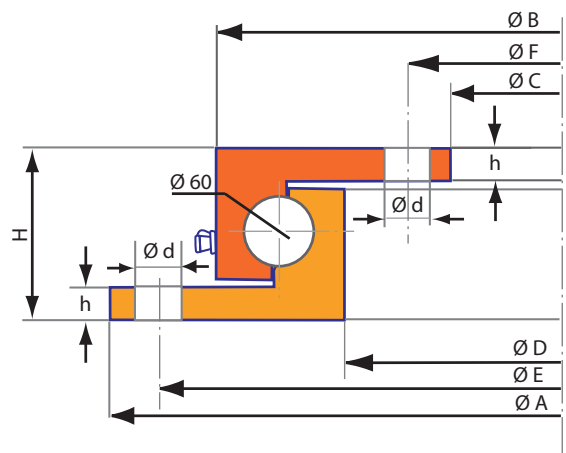
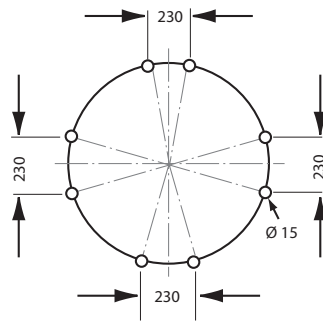

Type	Ø A mm	Ø B mm	Ø C mm	Ø D mm	Ø E mm	Ø F mm	h mm	Ø d mm	H mm	Weight (kg)	Axial-load (t)
HB 950ND	952	885	750	821	920	780	12	15	60	50	6,0
HB 1100ND	1102	1027	890	963	1070	920	12	15	60	70	7,5

Please observe our maintenance and monting guidelines



Helmut Buer GmbH & Co. KG
Am Leveloh 11
D-45549 Sprockhövel

Tel: +49(0)2324/90291-0
Fax: +49(0)2324/77 33-0
Email: info@buer-kg.de
Web: www.buer-kg.de