

KUGELLENKKRÄNZE

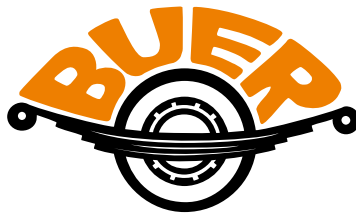



Baureihe ZG

Z-Profil

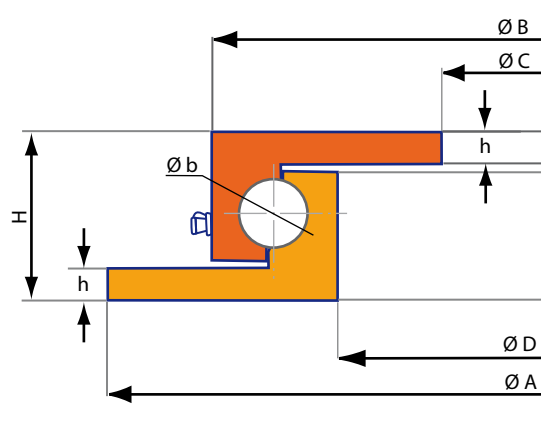

Typ	Ø A mm ±5	Ø B mm	Ø C mm	Ø D mm	Ø b mm	h mm	H mm	Axial- Last (t)
HB-500 ZG	500	437	310	379	16	10	52	1,8
HB-650 ZG	650	587	465	523	16	10	52	2,5
HB-750 ZG	750	687	565	620	16	10	52	3,0
HB-850 ZG	850	787	665	723	16	10	52	3,5
HB-950 ZG	950	887	752	820	16	10	52	4,0
HB-1050 ZG	1050	987	865	923	16	10	52	4,5

Bitte beachten Sie unsere Einbau- und Wartungsanleitung

Gebohrte Ausführung auf Anfrage



Helmut Buer GmbH & Co. KG
Am Leveloh 11
D-45549 Sprockhövel

Tel: +49(0)2324/90291-0
Fax: +49(0)2324/77 33-0
Email: info@buer-kg.de
Web: www.buer-kg.de

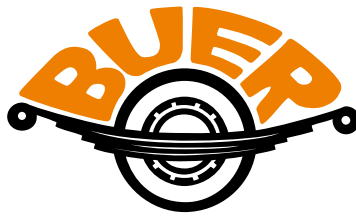

Kugellenkranz 400L

Z-Profil

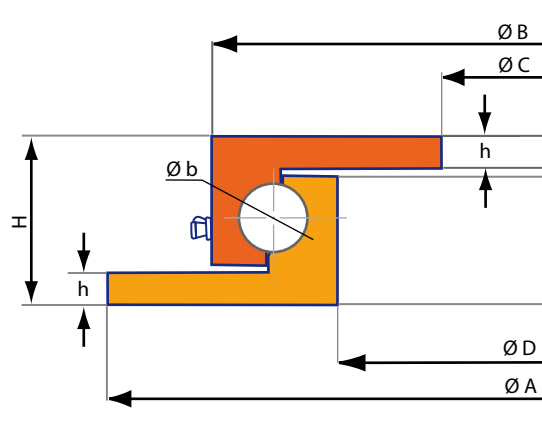

Typ	Ø A mm	Ø B mm	Ø C mm	Ø D mm	Ø b mm	h mm	H mm	Axial- Last (t)
HB-400 L	400	342	230	292	13	8	45	40

Bitte beachten Sie unsere Einbau- und Wartungsanleitung

Gebohrte Ausführung auf Anfrage!



Helmut Buer GmbH & Co. KG
Am Leveloh 11
D-45549 Sprockhövel

Tel: +49(0)2324/90291-0
Fax: +49(0)2324/77 33-0
Email: info@buer-kg.de
Web: www.buer-kg.de

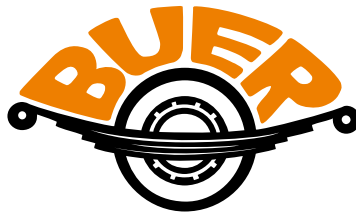

HB 400L gebohrt

Z-Profil

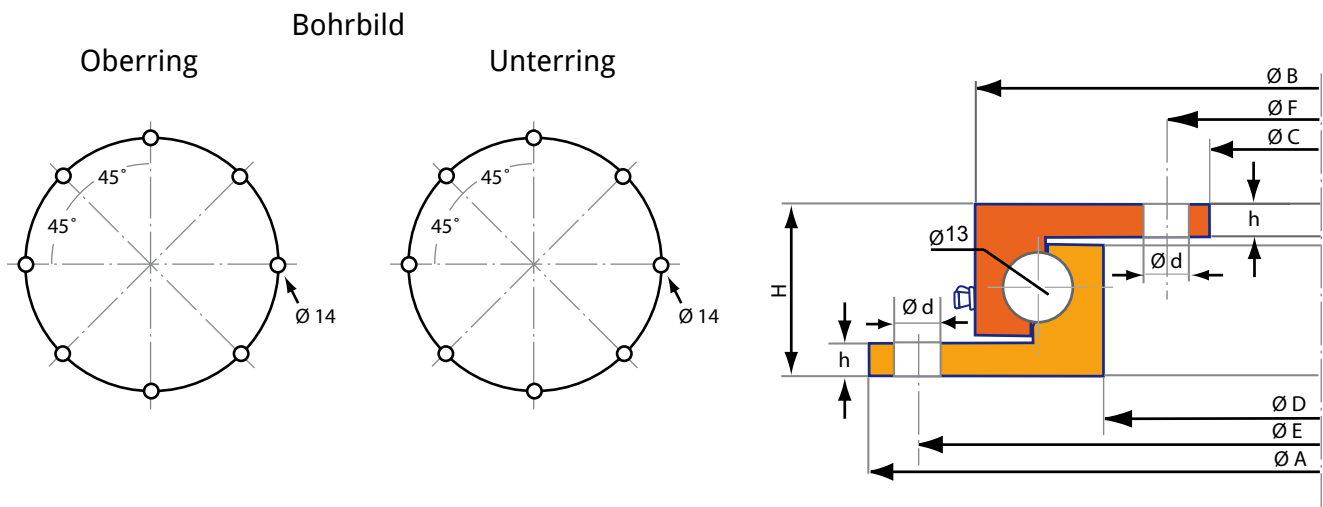

Typ	Ø A mm	Ø B mm	Ø C mm	Ø D mm	Ø E mm	Ø F mm	h mm	Ø d mm	H mm	Gewicht (kg)	Axial-Last (t)
HB 400L [gebohrt]	400	342	230	292	375	260	8	15	45	11	40

Bitte beachten Sie unsere Einbau- und Wartungsanleitung



Helmut Buer GmbH & Co. KG
Am Leveloh 11
D-45549 Sprockhövel

Tel: +49(0)2324/90291-0
Fax: +49(0)2324/77 33-0
Email: info@buer-kg.de
Web: www.buer-kg.de